

SQUARE HINGES WITH BALL BEARINGS TO WELD

Description

Pair of galvanized hinges with ball bearing and mounting plate suitable for tubular frames. They are fixed by welding to the frame. Fixing to the column through screws or bolts.

Articles family

VC4351-VC4352

The table below shows each pair of hinges settings correspondent (G) and the profile size in mm.

| Article Code | G | Profile Size |
|--------------|-------|--------------|
| VC4351.040 | 52÷62 | 40x40 |
| VC4352.050 | 52÷62 | 50x50 |

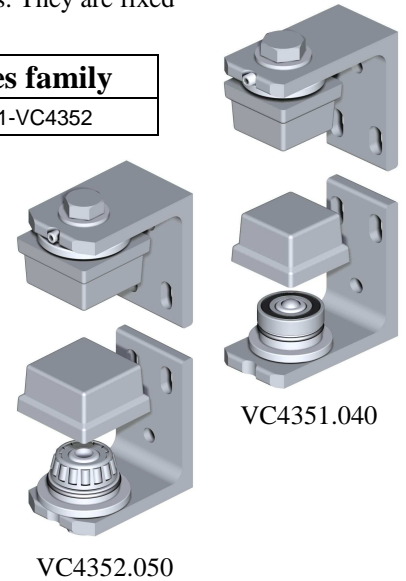

Assembly sequence.

| | | |
|--|---|---|
| | | |
| <p>1) Insert the square inserts in the profile and weld around the edge.</p> | <p>2) Positioned the gate in the final position. Mark and drill the holes on the column. After drilling fix the hinge's bracket in place.</p> | <p>3) To adjust the gate act on the nuts and the pin.</p> |

Maintenance

To maintain this product in optimum condition of efficiency and safety, simply:

1. Make sure after installation and after carrying out a few opening and closing sequences that nothing has slackened; in any case, check periodically that there is no loosening caused by vibration, blows, etc.
2. Make sure that the gate leaf does not drop, shall this happen, check the bottom hinge and reset if necessary.
3. In the event of blows from moving vehicles and other factors, make sure that the hinges and parts for supporting and moving the gate have not been altered in any way or that their operation has not been affected.

Scelta del cardine

Having calculated the A/H ratio of the gate in question (see figure) find the point in the graph that corresponds to the weight of the gate. The articles usable are those whose curve is above this point. If the weight of the gate is not distributed evenly, the value of A must be considered equal to twice the distance between the centre of gravity of the gate and the axis of rotation of the wing.

Solution fo a pair of hinges

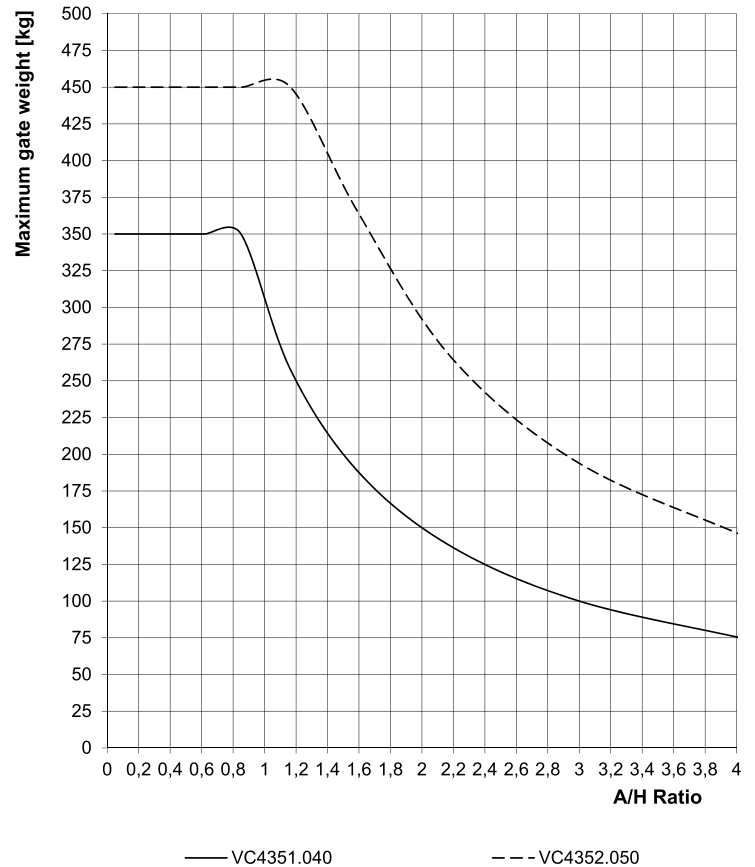
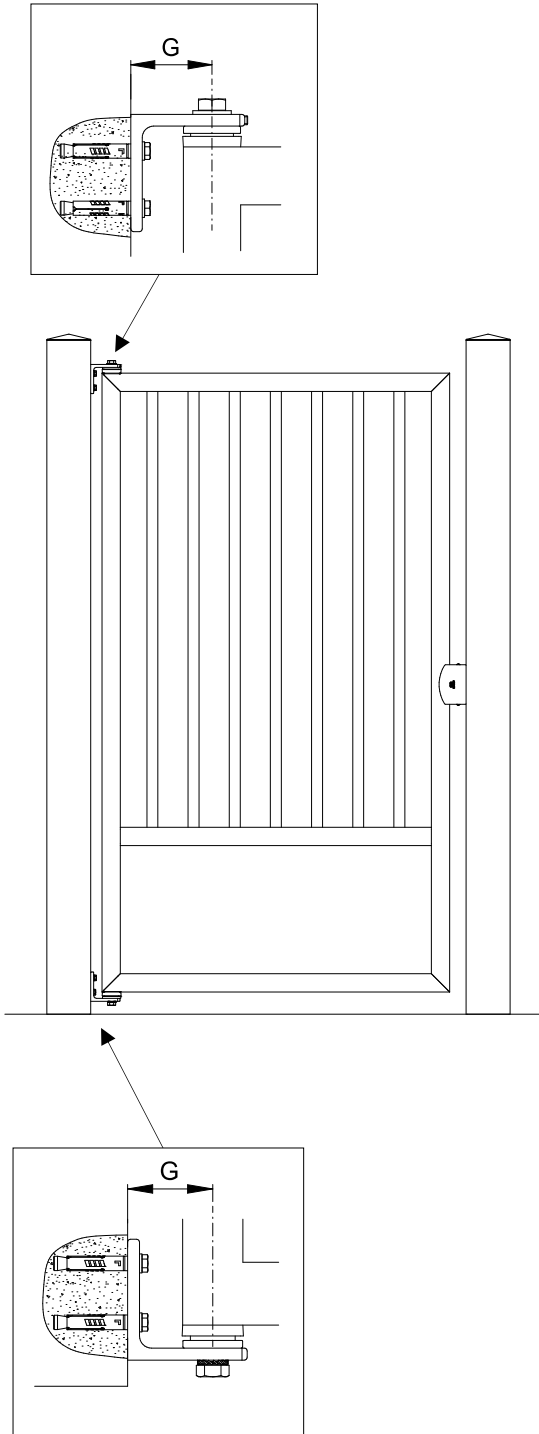

Attention: installations that do not comply with the illustred procedure or or failure to carry out correct maintenance operations can cause the gate to derail and endanger the safety of persons and propriety